

hydroo[®]

NDROO SERIES

HZ

**Polymeric end
suction pump
50Hz**



PRESENTATION

Hydroo Pump Industries SL is an enterprise specialised in the research, development and large-scale production of Stainless Steel centrifugal pumps. We have a vertical integration of the production processes, standing out stamping, welding and motor wiring in 6 value centers and production units. All of them with a high performance management on pump engineering and production quality.

HYDROO has set up a wide range of pumping solutions for many applications as building services, industry, irrigation and industrial process. Customers enjoy of the highest performance in booster sets and pressurization, fire-fighting sets, pumping of underground water, HVAC, drainage and sewage, utilities, desalination and OEM integrations. Versions in 50 Hz and 60 Hz are available, as well as any modification on materials, on request.

Global water challenges require excellence in pumping technologies

and close cooperation between pump designers, manufacturers and pump engineers. In order to better meet the customers' needs and requirements our company is facing an expansion of its operations worldwide, providing timely and effective services in more than 30 countries. With tight relationships in many regions, we're proud to introduce a new regional value center for Europe. We are based near Barcelona at the Girona industrial area. Hydroo is a trademark to forge excellent and successful business relationships with our value customers by means of an operative assembling unit and an application engineering unit. HYDROO trademark wants to symbolize the firm commitment for a high level service to our value partners.

At Hydroo we bet on a high level service to our value pump partners.

HZ

Polymeric end suction pump

Applications

Alkali & acid production
 Metal smelting industry
 Chemical synthesis
 Paper-making industry
 Textile dyeing and finishing systems
 Pickling processes in electroplating
 Other corrosive liquids transferring

Description

HZ pump has one impeller, axial suction and radical discharge.

Simple structure, shaft is directly connected with impeller.

Easy for pipe works, inlet and outlet are connected by standard flanges.

Wet parts are made in polymeric fluorine, accessories are made of cast iron (GG20).

Performance range

Flow range: 2.2 ~ 60 m³/h

Head: 16 ~ 52 m

Temperature: -20 °C ~ +120 °C

Speed: 2900 rpm

Power: up to 18,5 kW

Standard material

F42, F46, GG20



Definition of model

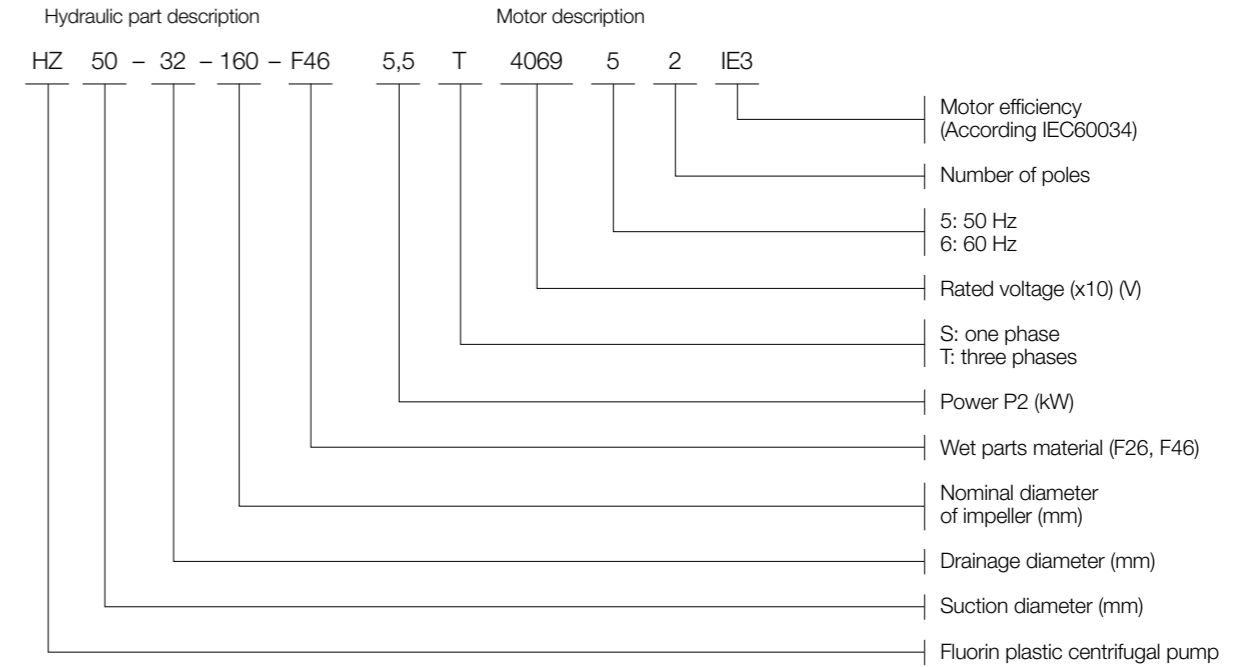

Performance scope

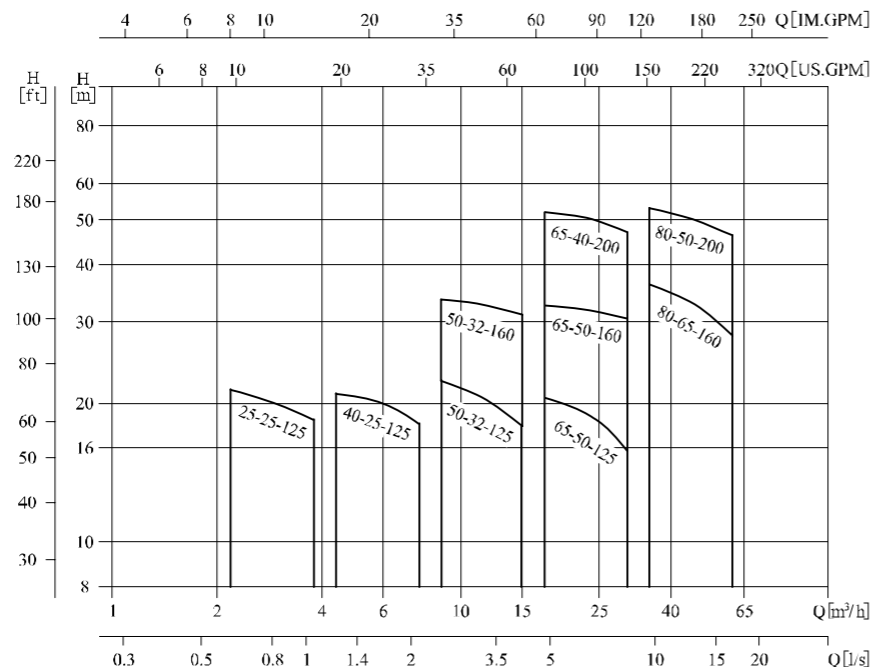

Structure feature

- HZ pump has one impeller, axial suction and radical discharge.

- Simple structure, shaft is directly connected with impeller.

- Easy for pipe works, inlet and outlet are connected by standard flanges.

- Wet parts are made of F26. F46, accessories are made of cast iron (HT200).

Typical application

- Any concentration of acid alkali, salty solution, strong oxidants, organic solvent etc. Strongly corrosive medium.

- Petrol, chemical, pesticide, acid cleaning, dying, paper making, galvanization, etc.

Operation conditions

- Thin medium not containing grain or fiber.

- Medium temperature: -20°C-120°C

- Medium density: Max 1.35x 103kg/m³

- Ambient temperature: Max+40°C

- Altitude: Max 1000m

- Pressure: Max 10bar

Motor

- TEFC motor, 2 pole

- Protection class: IP 55

- Insulation level: CLASS F

- Standard voltage: 3x380V

Curve conditions

- Curves tolerance is according to 1509906, Annex A;

- All curves are based on the measured value of constant motor speed 2900 rpm, 3 x 380V.

- The measurements were made with airless water at temperature of 20°C. The curves apply to a kinematic viscosity of 1mm²/s(1 cst)

- It is suggested to operate the pump in the scope of the bold curve, to prevent motor from overload.

- When pumping liquids with a density higher than that of the operation conditions, use motors with correspondingly higher outputs.

Performance curve

- Q/H: means the curve of the flow and head at the nominal rotating speed.

- Power curve: P2 means the pump input power, if the medium density is 1 x 103kg/m³.

- Efficient curve: Eta means the pump efficiency.

Installation conditions

- When installation, please make sure the pump would not be effected by the pipeline force when pump operation.

- The pump should be strongly fixed on the horizontal base.

- In order to make motor work well, pump should be installed on the frozen free and ventilate place.

- The electric protection devices should protect pump from being damaged by phase lack, unstable voltage, electric leakage, overload.

Performance table

Model	Nominal flow (m³/h)	Nominal head (m)	Flow range (m³/h)	Max bar (bar)	Power (kW)	Max efficiency (%)
HZ25-25-125	3.2	20	2.2~3.8	2.1	1.1	28
HZ40-25-125	6.3	20	4.4~7.6	2.1	1.5	41
HZ50-32-125	12.5	20	8.8~15	2.3	3	44
HZ50-32-160	12.5	32	8.8~15	3.3	4	51
HZ65-50-125	25	20	17.5~30	2	4	55
HZ65-50-160	25	32	17.5~30	3.3	5.5	60
HZ65-40-300	25	50	17.5~30	5.1	11	55
HZ80-65-160	50	32	35~60	3.6	11	62
HZ80-50-300	50	50	35~60	5.4	18.5	63

Section drawing

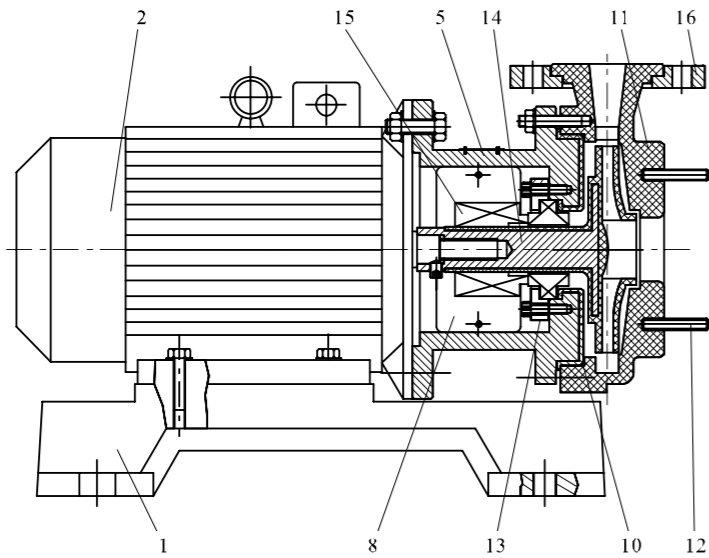

Part list

No.	Name	Material	Code/AISI/ASTII
1	Base	HT200	ASTM25B
2	Motor		
5	Injection moulding pump head	HT200+F26(F46)	ASTM25B+F26(F46)
8	Guard	Stainless Steel OCR18Ni9	AISI304
10	O ring	FPM	
11	Casing	F26(F46)	
12	Double end studs	Stainless Steel OCR18Ni9	AISI304
13	Seal cover	HT200	ASTM25B
14	Impeller	Steel+F26(F46)	ASTMA570+F26(F46)
15	Mechanical seal	Silicon Carbide/Silicon Carbide	
16	Outlet flange	HT200	ASTM25B

HZ 25, 40, 50

Performance curve 2900rpm

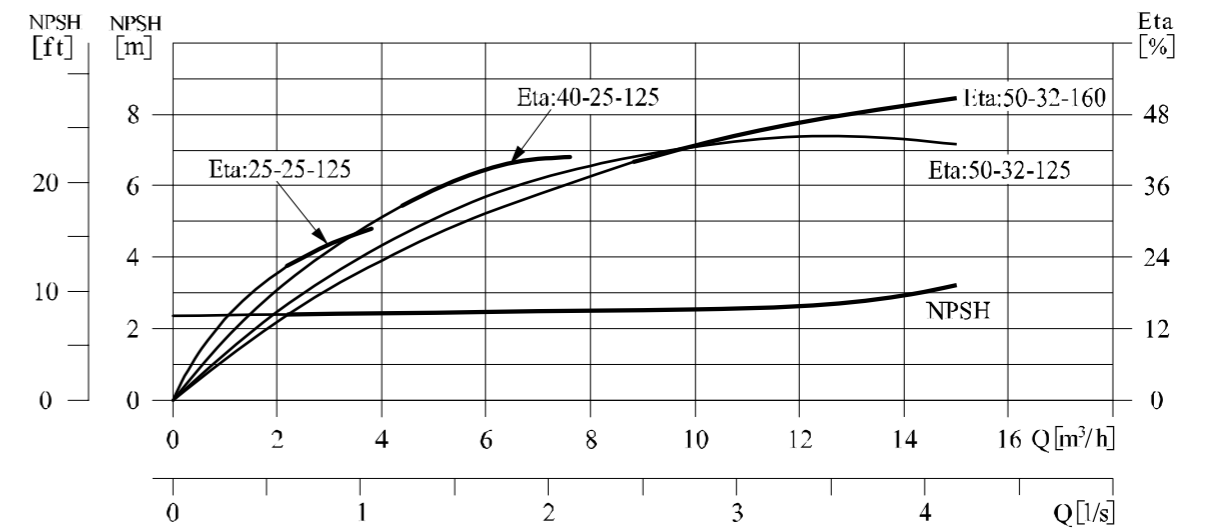
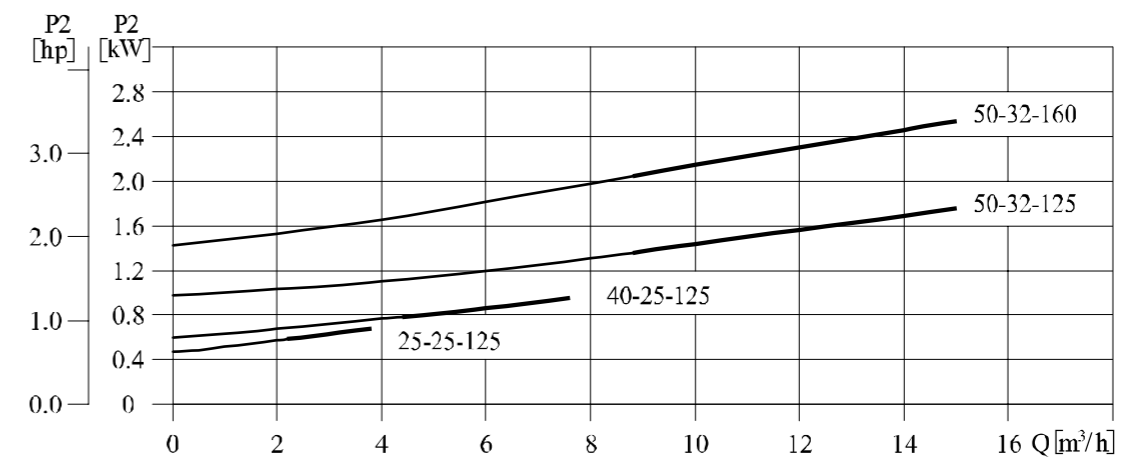
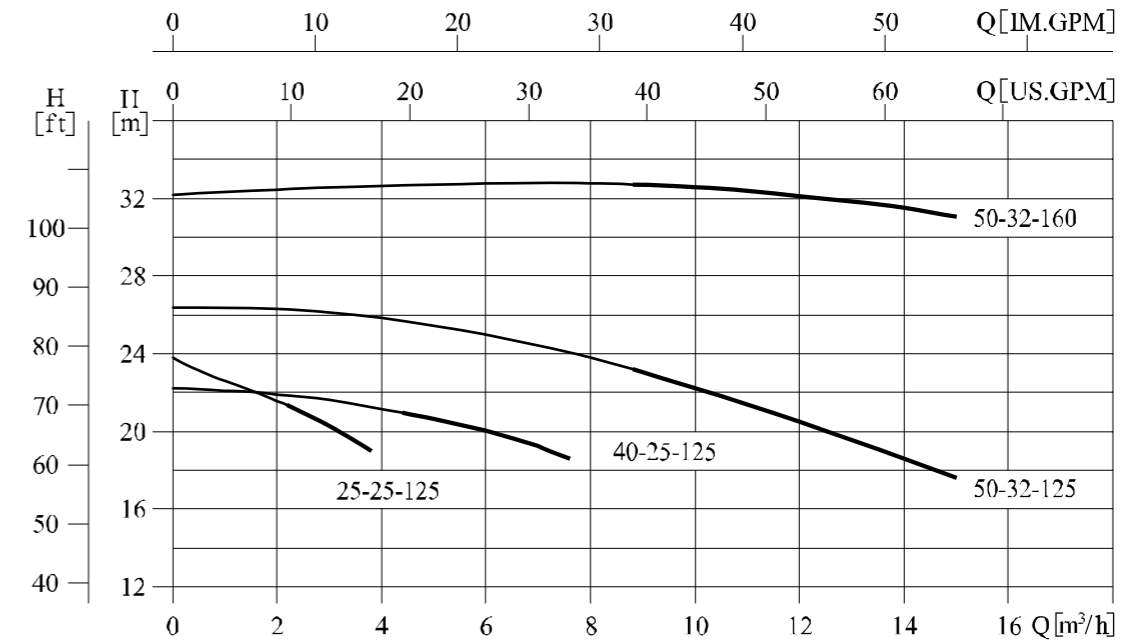

HZ 65

Performance curve 2900rpm

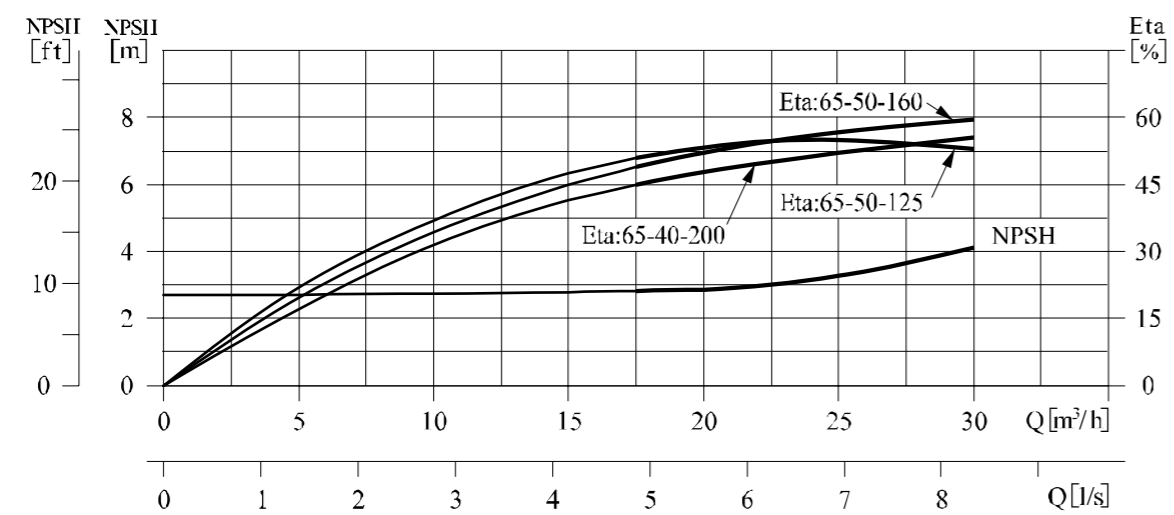
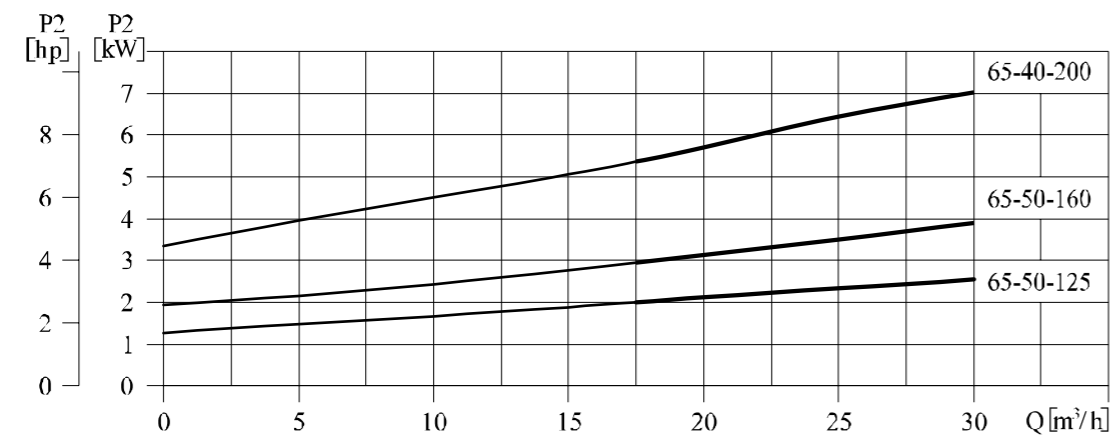
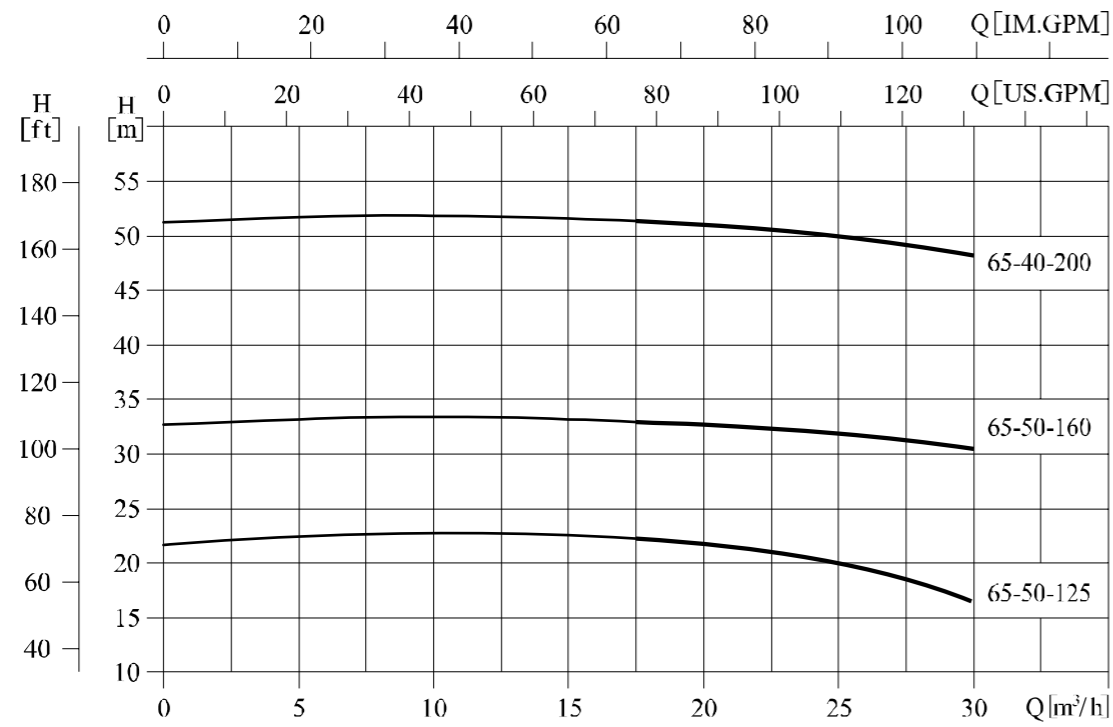

HZ 80

Performance curve 2900rpm

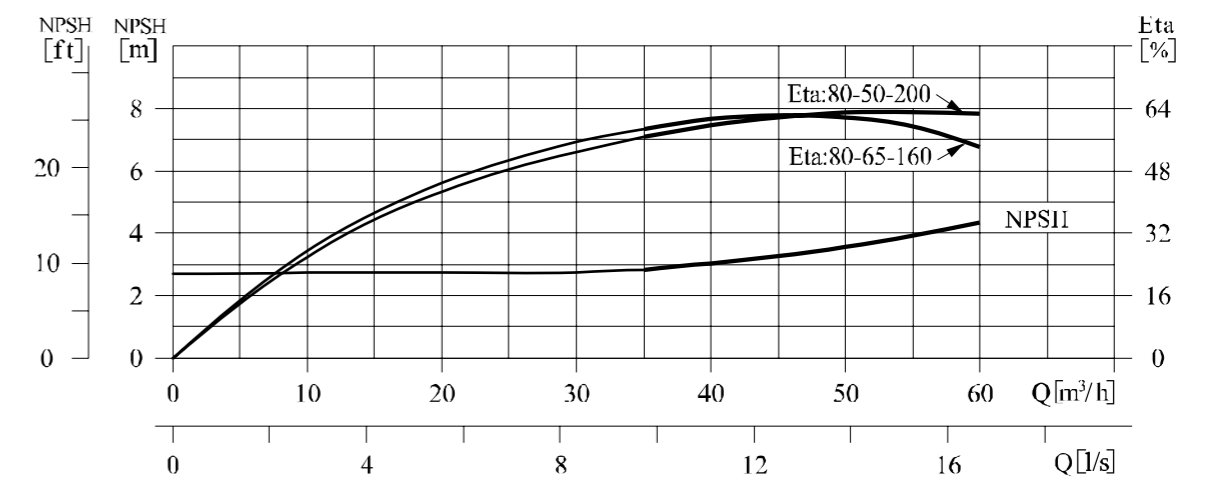
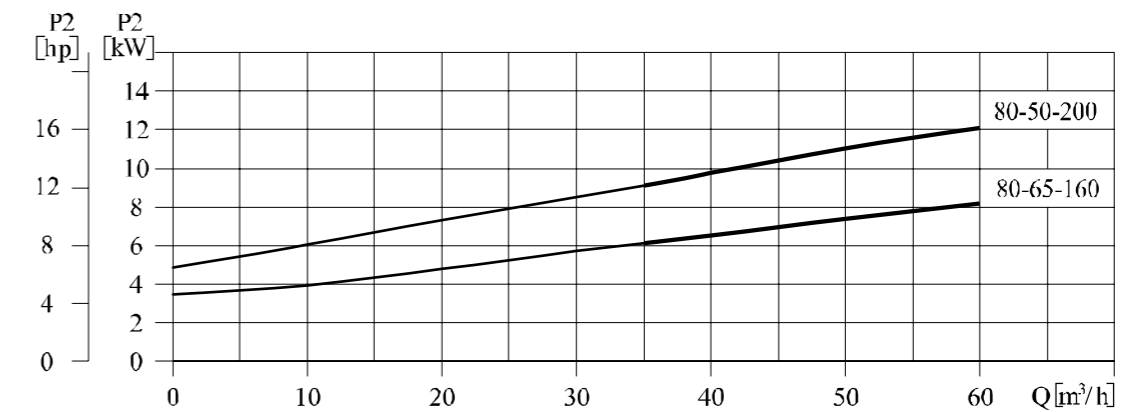
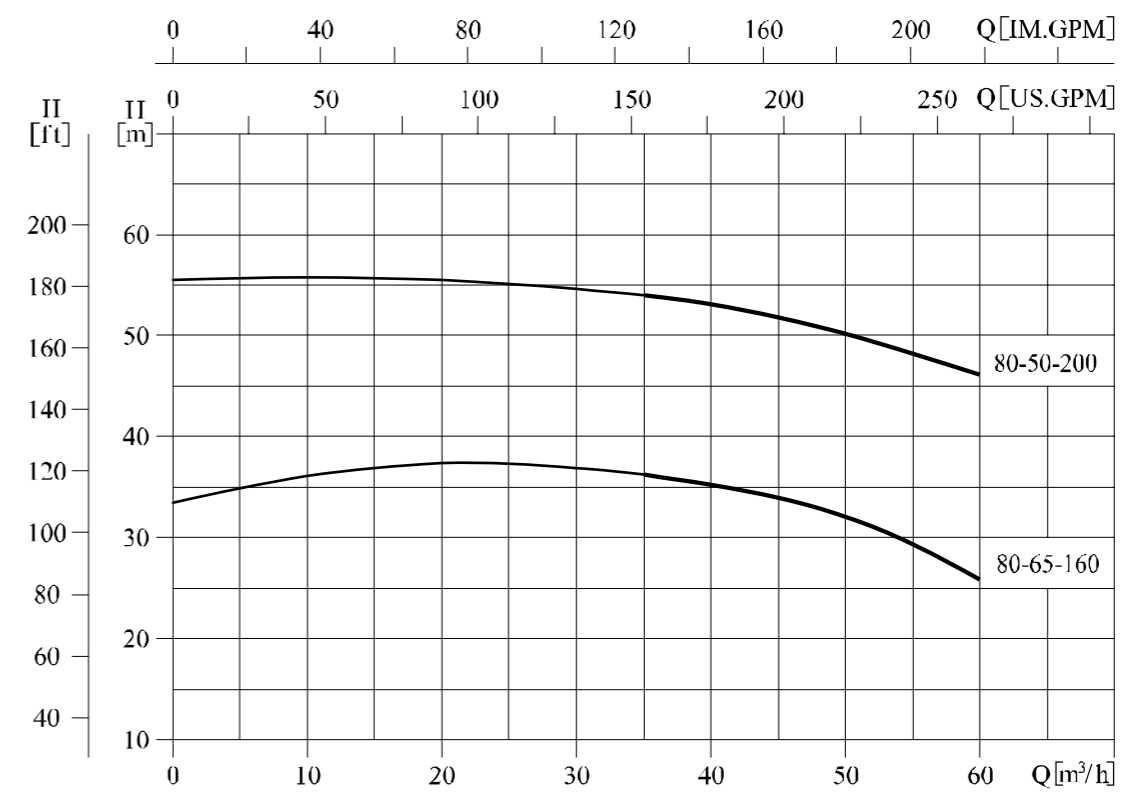

Installation sketch

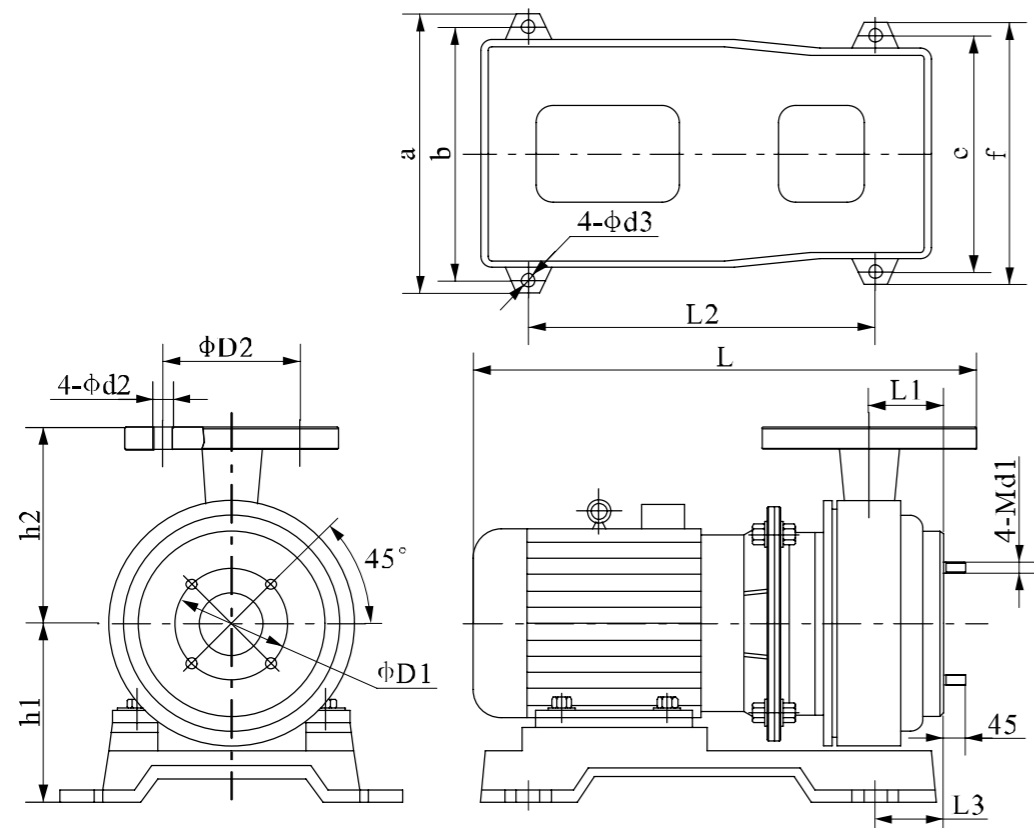

Size and weight

Model	Size (mm)																Weight (kg)	
	L	L1	L2	L3	D1	Inlet flange	d1	h1	h2	D2	Outlet flange	d2	a	b	d3	e		f
HZ25-25-125	457	37	300	64	75	DN25/PN6	10	164	120	100	DN32/PN10	14	265	230	15	230	265	45
HZ40-25-125	461	37	300	72	100	DN40/PN6	10	165	120	100		14	265	230	15	230	265	48
HZ50-32-125	531	43	370	79	125	DN50/PN10	14	175	140	100		14	275	235	17	235	275	74
HZ50-32-160	553	53	370	103	125	DN50/PN10	14	191	159	100	14	315	270	17	270	315	78	
HZ65-50-125	563	50	370	95	145		DN65/PN10	14	175	147	125	18	315	270	17	270	315	79
HZ65-50-160	618	51	400	88	145			14	219	165	125	18	370	330	17	290	335	113
HZ65-40-200	727	55	440	96	145	DN40/PN10	14	255	180	110	18	425	380	19	320	365	181	
HZ80-65-160	750	57	440	97	160	DN80/PN10	14	255	186	145	DN65/PN10	18	425	380	19	320	365	183
HZ80-50-200	797	57	440	110	160		DN50/PN10	14	255	195	125	18	425	380	19	320	365	205

F46, F26 corrosion resistance table

Medium	F46	F26	Medium	F46	F26	Medium	F46	F26
Acetic acid; benzene	√	√	Sulfuric Acid +20% Smoke sulfate	√/80°C	—	Titanium tetrathloride; zinc chloride	√	√
Arsenate; boric acid	√	√	Smoke sulfate	√	×	Ferric trichloride; carbon tetrachloride	√	√
Carbonate	√	√/20°C	Sulfurous acid	√	√	Salt solution; seawater	√	√
Fluoride acid	√	—	Ammonium hydroxide, potassium hydroxide	√	√	Alum (slurry); black liquor (slurry)	×	—
Hypochlorite; wet chlorine	√	√	Sodium hydroxide <20%	√	√	Blue alum; NaHSO3	√	√
Chromic acid	√	√/50°C	Sodium hydroxide <80%	√	×	Sodium bicarbonate; soda	√	√
citric acid	√	√/120°C	Calcium hydroxide	√	√	Sodium hypochlorite	√	√/20°C
Toluene acid	√	√/65°C	Acetic acid salt solution	√	√	Sodium chlorate; calcium chloride	√	—
Formic acid	√	√	Ammonium nitrate; barium nitrate	√	√	Chromium sodium	√	—
Glycolic acid	—	√/20°C	Sodium nitrate; copper nitrate	√	√	Al acetic	√	√
Hydrochloric acid	√/65°C	√/37°C	Iron nitrate	√	√	Bromine	√	√/20°C
Hydrofluoric acid; fluorosilicic acid	√	√	Nitrate lead; silver nitrate	√	—	Glycerol	√	√
Hydrogen peroxide; lactic acid	√	√/20°C	Aluminium sulfate, ammonium sulfate	√	√	Pyridine	√	×
Maleic acid; malic acid	√	√	Ammonium sulfate + sulfuric acid	√	√	Acetic (acid) anhydride	√	√/20°C
Mixed acid	√	—	Barium sulfate; sodium sulfate	√	√	Aniline dye; hydrochloride aniline	√	—
Oleic acid	√	√	Copper sulfate	√	√	Methane, ethane, propane	√	√
Oxalate acid	√	√/50°C	Copper sulfate +10% sulfuric acid	√	—	Nitrobenzene	√	√/20°C
Picric acid, stearic acid	√	√/20°C	Ferrum sulfate +10% sulfuric Acid	√	—	Tar and ammonia	√	—
Tartrate; Tannin	√	√	Magnesium sulfate; zinc sulfate	√	√	Toluene; SO3	√	√
Nitrate 5% to 10%	√	√/50°C	Ammonium; sodium	√	√	Glycol; ethylene oxide	√	√
Nitric Acid <50%	√	√	Chloride; barium chloride	√	√	Two-acetone; dichloro-ethanol	√	√/20°C
Concentrated nitric acid	√	×	Calcium chloride	√	√	Ethylene dichloride; vinyl trichloride	√	√
Nitric Acid +3.5% hydrofluoric acid	√	—	Aluminum trichloride	√	√/20°C	Formaldehyde	√	√/50°C
Phosphoric acid	√	√	Potassium chloride	√	√/65°C	Freon	×	—
Phosphoric acid +2% sulfuric acid +1% Hydrofluoric acid	√	—	Sodium chloride; tin chloride	√	√	CS2	√	√/20°C
Sulfuric acid <10%	√	√	Silver chloride, magnesium chloride	√	√	Molten sulfur	√	√
Sulfuric acid 10% to 75%	√	√/65°C	Nickel chloride	√	√			
Sulfuric acid 75% to 98%	√/80°C	√/50°C	Sulphur dichloride	√	√/20°C			

Note: 1. √/20% means the material can be used in the medium that temperature is below 20°C; √ means workable; × means doesn't work; — means not known.
2. √/20% means the material can be used in the 20% medium.

hydroo®

Be pumping partners

HYDROO
Pump Industries SL

Carrer La Banyeta Nova, 11
Polígon Industrial La Banyeta
17843 Palol de Revardit
Catalonia. Spain
Tel. +34 972 394 654
E-mail: info@hydroo.com
www.hydroo.com

201847-CTL-HZ-EN
subject to amendments

